

REV.	DESCRIPTION	ECN	DATE	BY
A	NEW DRAWING	C4710	6/18/07	JFF
B	TABULATED -01,-02	C4710	7/18/07	JFF
C	CHARTED ITEM #5	11/16/07	11/16/07	JFF
D	ADDED ITEM #6	C5054	1/02/07	JFF
E	ADDED -03 CONFIGURATION	7444	3/19/2010	GWE

ITEM #	PART #	QTY	DESCRIPTION
1	19007-85	1	PRESSURE PROTECTION VALVE
2	CHART	1	CONTROL PANEL ASSEMBLY
3	17347	1	12V RELAY
4	CHART	1	LIFT CONTROL MODULE
5	CHART	1	REGULATOR MOUNTING BRACKET
6	LIT19516	1	VALVE INSTRUCTIONS

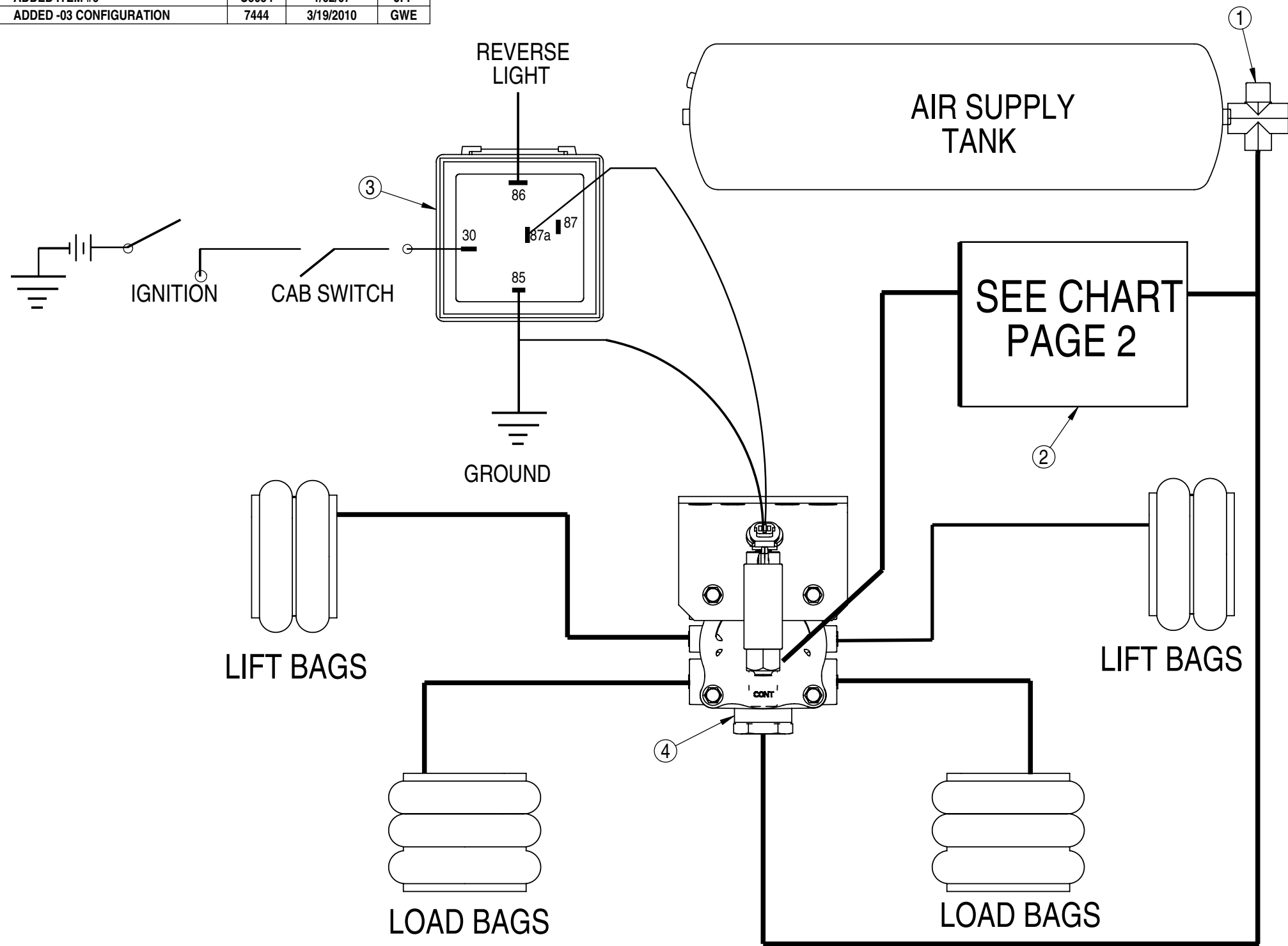

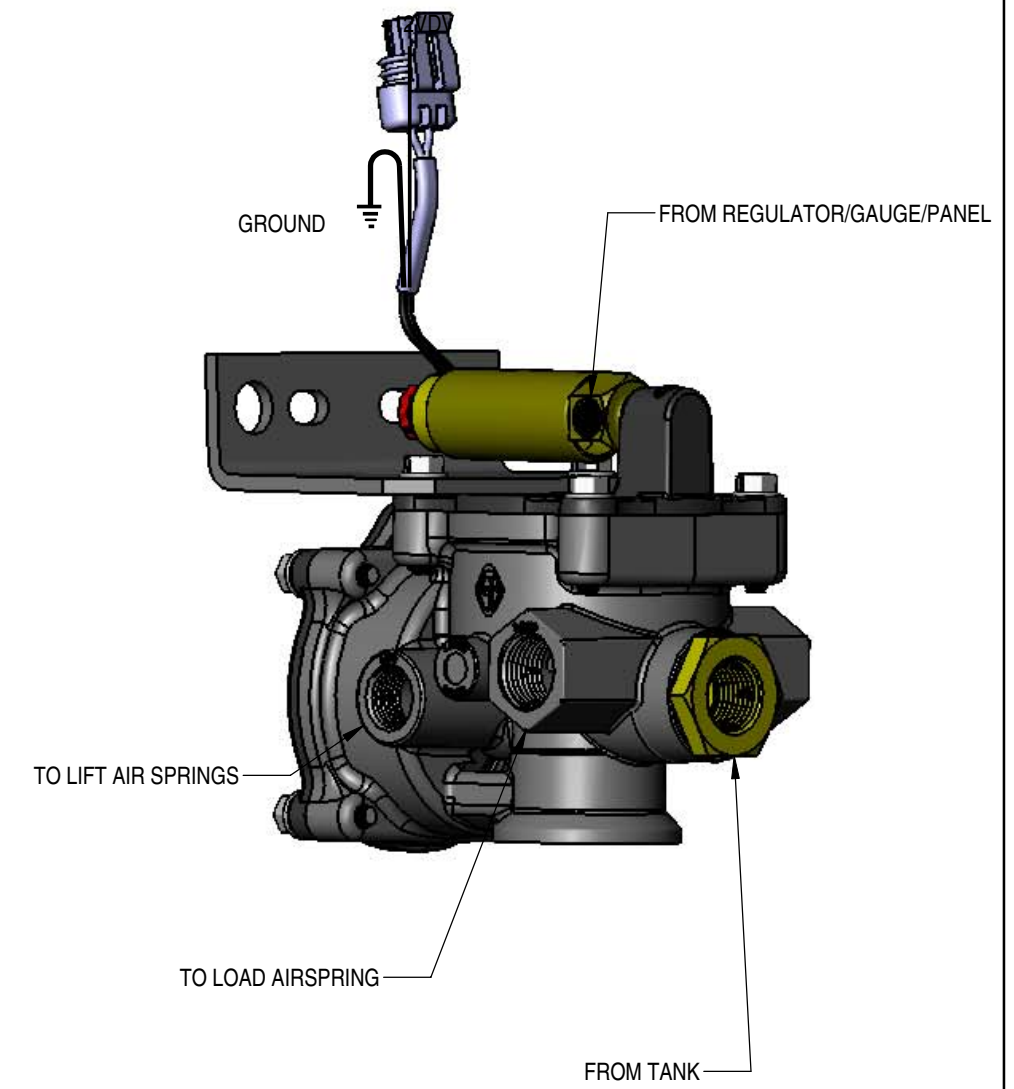



△ E
△ D

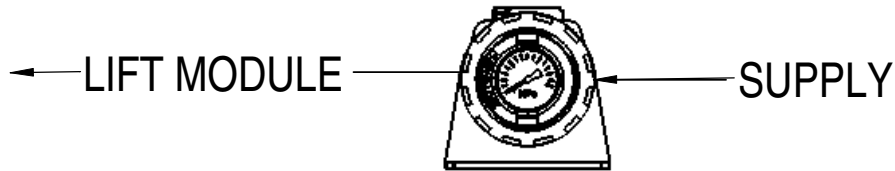
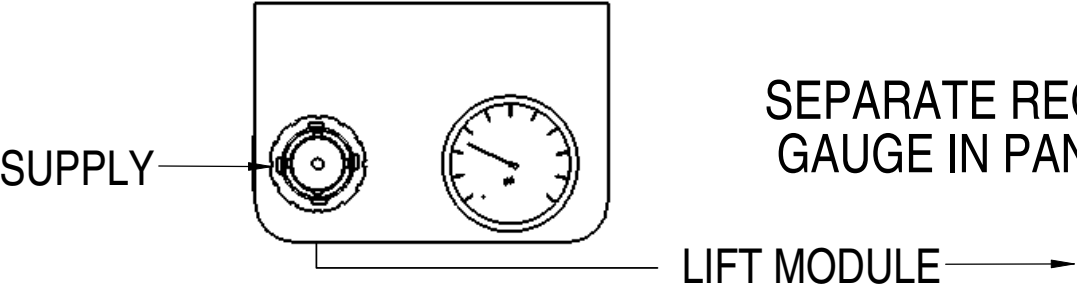

NOTE:
1. ALL NYLON TUBING AND FITTINGS FURNISHED BY CUSTOMER (EXCEPT CONTROL PANEL)

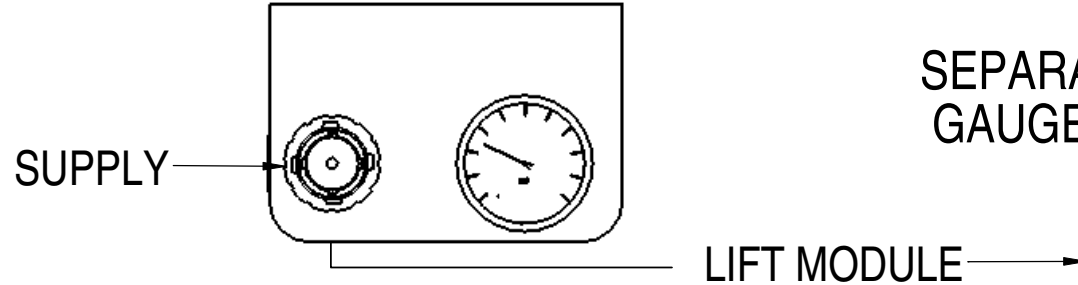
TOLERANCES (EXCEPT AS NOTED)	DESCRIPTION: AIR CONTROL KIT		
DECIMAL ± .06	PREVIOUS ASSY: ACK	SHEET: 1 OF 2	 Watson Suspension Systems
FRACTIONAL ± 1/16	SUSPENSION MODEL: VARIES	SCALE: 1:1	
ANGULAR ± 1°	DATE: 6/18/07	DRAWN BY: JFF	SIZE: B
			DRAWING NO: ACK250

PART #	APPLICATION	ITEM #2	ITEM #5	ITEM #4
ACK250-01	 <p>REGULATOR WITH BUILT IN GAUGE/ MOUNTING BRACKET</p>	19535	19535B	19516-711
ACK250-02	 <p>SEPARATE REGULATOR AND GAUGE IN PANEL</p>	990099	N/A	19516-711
ACK250-03 	 <p>SEPARATE REGULATOR AND GAUGE IN PANEL</p>	990099	N/A	19516-311

TOLERANCES (EXCEPT AS NOTED)		DESCRIPTION: AIR CONTROL KIT		
DECIMAL + .06	PREVIOUS ASSY: ACK	SHEET 2 OF 2		 <p>Watson Suspension Systems</p>
FRACTIONAL + 1/16	SUSPENSION MODEL: VARIES	SCALE: 1:12		
ANGULAR + 1°	DATE: 6/18/07	DRAWN BY: JFF	SIZE: B	DRAWING NO: ACK250

Lift Axle Control Module (LACM) Air Line Connections

A. Overview

The GT Lift Axle Control Module controls airflow to and from and the Lift and Load (Ride) bags of an auxiliary axle. There are three main valve types:

AIR ONLY

NORMALLY CLOSED
SOLENOID

NORMALLY OPEN
SOLENOID

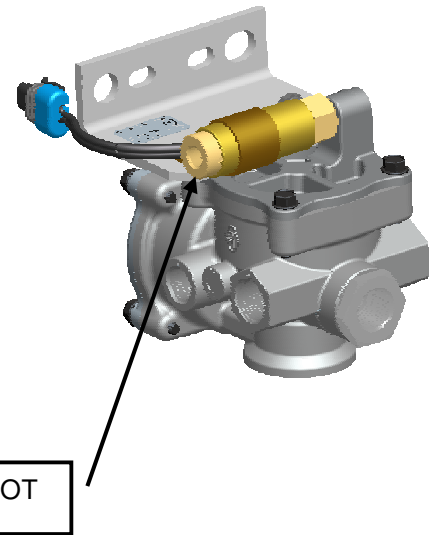
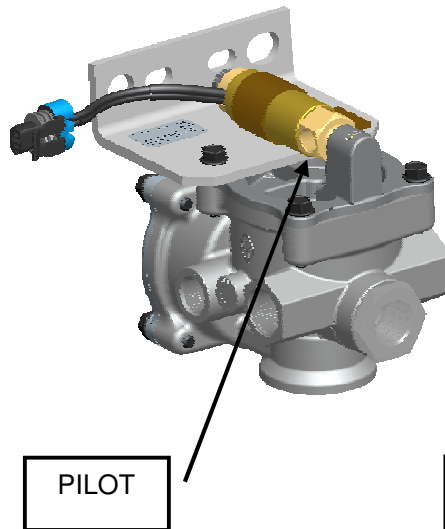
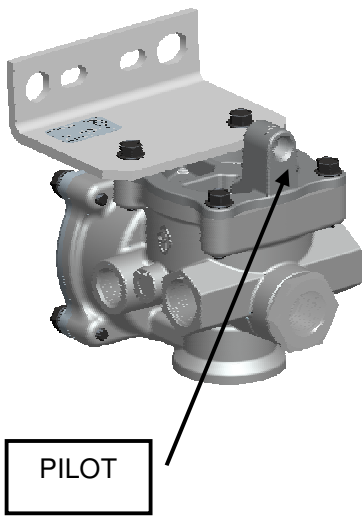



B. Mounting

1. Mount the LACM to an adequate flat surface using 1/2" (M12) or 5/16" (M8) fasteners.
2. Mount the LACM **ONLY** with the exhaust vent facing downward. Failure to do so will prevent contaminants from exiting the valve and may cause valve failure.

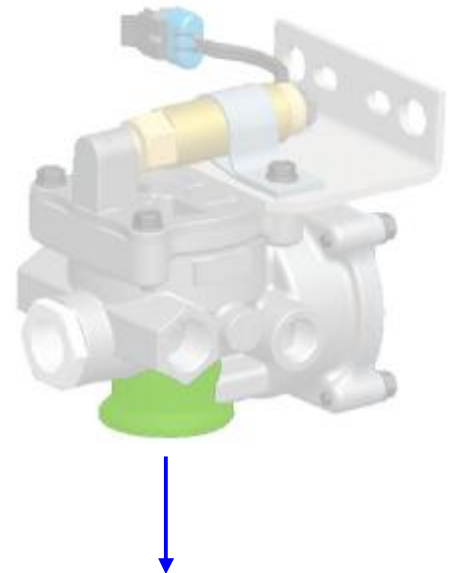
Mount **ONLY** with exhaust facing downward



REV	CHANGE: DCR 2304	DATE: 7/17/07	TITLE: APPLICATION INSTRUCTION, LACM AIR LINE ASSY	Sheet 1 of 1
4X	ORIGINATOR: K. CURTIN	DATE: 7/17/07	 GT DEVELOPMENT CORPORATION A  NORGEN Company	

C. Air Connections

All LACM versions have 4 main (plus an optional gauge port) air line connection locations.

1. MAIN SUPPLY

The Main Supply port is the connection to the Supply air reservoir (downstream of the pressure protection valve). GT recommends use of a 1/2" Supply line to ensure adequate airflow.

Connect the Main supply to the axle's air reservoir, downstream of the PPV.

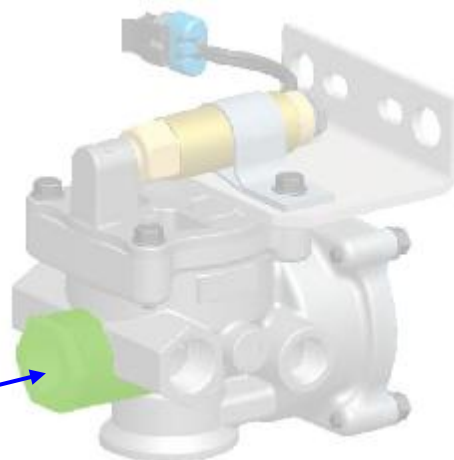

2. PILOT PORT (Control port)

The Pilot port is the connection to the auxiliary axle regulated pilot. The pilot port is connected downstream of the auxiliary axle regulator. GT recommends use of a 1/4" Pilot line. **The Pilot is connected to the inlet per Section A above.** (Normally Closed Solenoid shown)

Connect the pilot port to the axle's Load Bag Regulator.

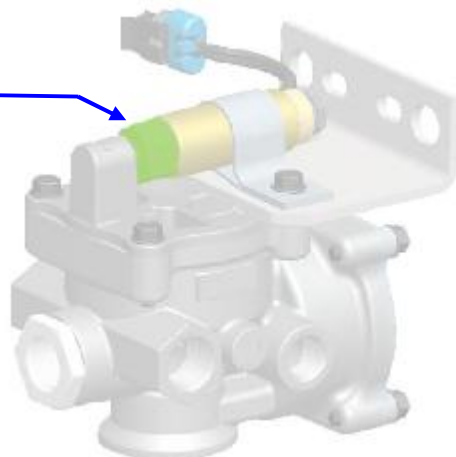



3. LOAD DELIVERY PORTS (2 per valve)

The Load delivery ports are the connection from the LACM to the Load (Ride) Bags. One port is connected to each Load bag. GT recommends use of 1/2" Load delivery lines to ensure adequate airflow.

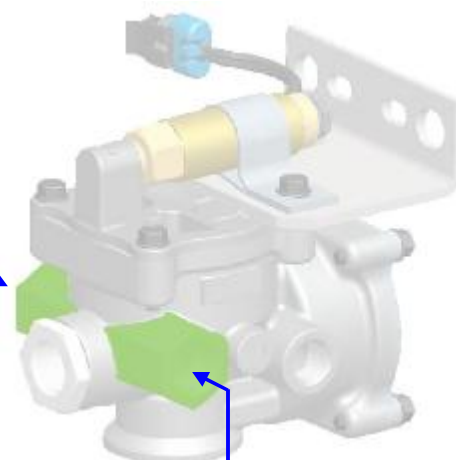
Connect the Load Delivery ports to the axle's Load bags.



REV	CHANGE:	DATE:	TITLE:	Sheet
4X	DCR 2304	7/17/07	APPLICATION INSTRUCTION, LACM AIR LINE ASSY	1 of 1
	ORIGINATOR:	DATE:	 GT DEVELOPMENT CORPORATION	
	K. CURTIN	7/17/07	A  NORGEN Company	

4. LIFT DELIVERY PORTS (2 per valve)

The Lift delivery ports are the connection from the LACM to the Lift bags. One port is connected to each Lift bag. GT recommends use of 3/8" Lift delivery lines to ensure adequate airflow.

Connect the Lift delivery ports to the axle's Lift bags.

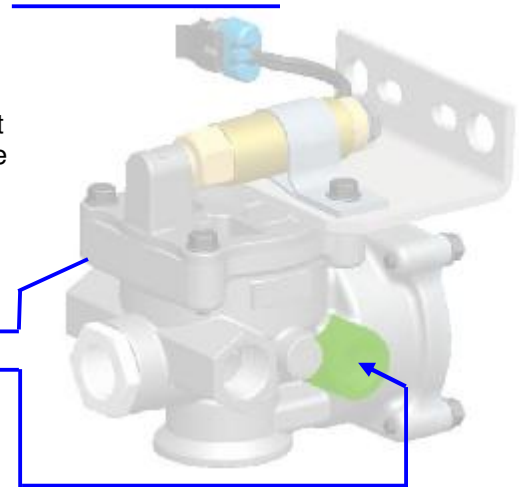

5. (OPTIONAL) GAUGE PORT

The optional Gauge port is common with the Load delivery ports. This port should be connected to the auxiliary axle's Load bag air pressure gauge.

Connect the Gauge port to the Load bag pressure gauge.

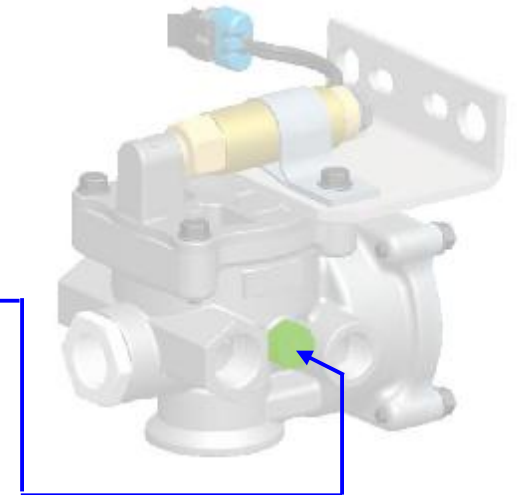

D. Electrical Connection

Solenoid equipped valves are either polarity sensitive or non-polarity sensitive. This characteristic can be confirmed by the colors of the wires:

1. Polarity sensitive:





Black - Common

Red - Positive

2. Non-Polarity sensitive:



Both White

REV	CHANGE: DCR 2304	DATE: 7/17/07	TITLE: APPLICATION INSTRUCTION, LACM AIR LINE ASSY	Sheet 1 of 1
4X	ORIGINATOR: K. CURTIN	DATE: 7/17/07	 GT DEVELOPMENT CORPORATION A  Company	

E. Typical Installation

Solenoid LACM, w/o gauge port
 Pressure Protection Valve (PPV) not shown

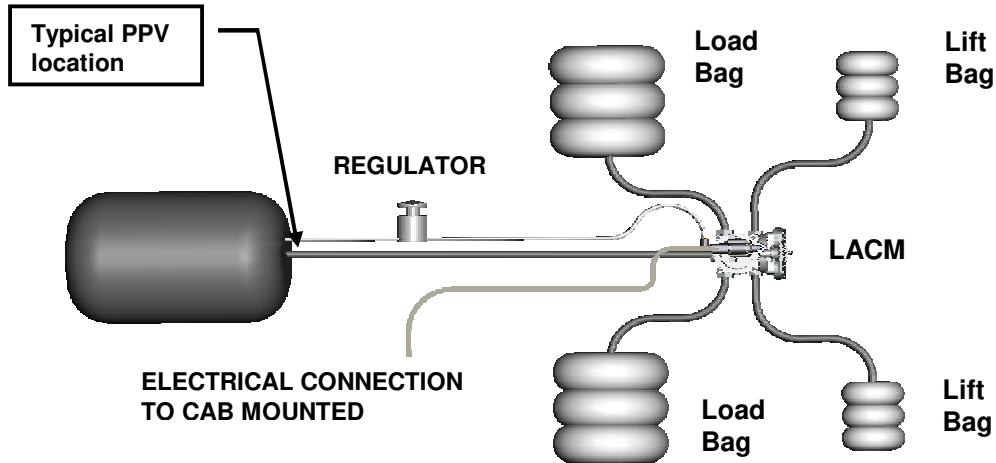



F. Pressure Protection Valve Replacement

If kit is equipped with a replacement Pressure Protection Valve (PPV), replace the PPV supplying the auxiliary axle. The main supply line (1/2") and pilot (1/4") are connected to the PPV.

Installation of the replacement PPV will ensure adequate airflow to the LACM.

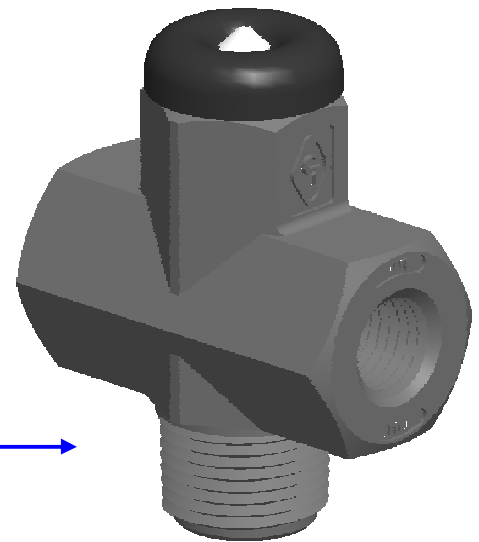
Replace the auxiliary axle PPV with the supplied unit.



REV	CHANGE:	DATE:	TITLE: APPLICATION INSTRUCTION, LACM AIR LINE ASSY	Sheet 1 of 1
4X	ORIGINATOR: K. CURTIN	DATE: 7/17/07	 GT DEVELOPMENT CORPORATION A  NORGREN Company	